

OUTLINE DRAWING & DIMENSIONS

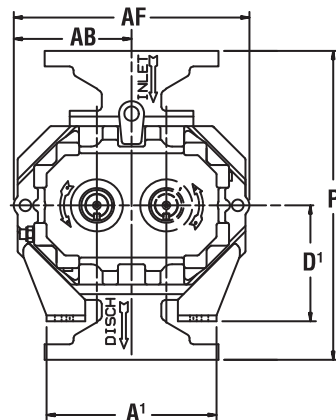
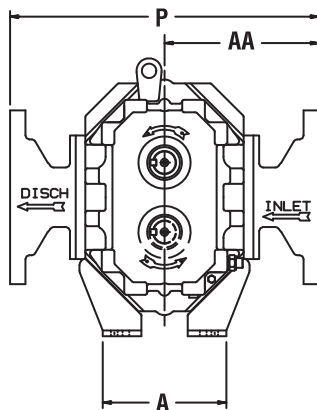
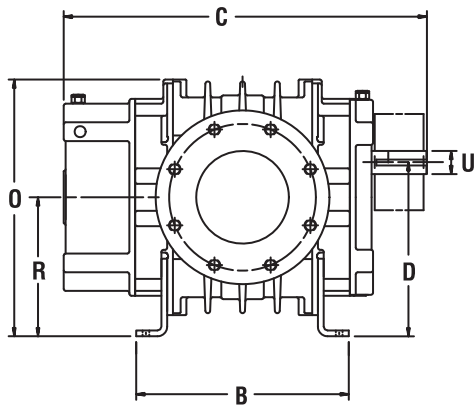

Dimensions are in inches (except U and Keyway are mm), weight is in pounds.

Model	A	A'	B	C	D	D'	O	P	R	U	Keyway	AA	AB	AF	Approx. Wt.
155	8	11	13.77	23.50	11.25	7.5	16.63	20.00	9.0	35	10.0 x 5.0	10.00	7.63	15.25	356
225	8	11	17.78	27.50	11.25	7.5	16.63	21.25	9.0	35	10.0 x 5.0	10.63	7.63	15.25	428
280	8	11	21.03	30.75	11.25	7.5	16.63	21.50	9.0	35	10.0 x 5.0	10.75	7.63	15.25	520
400	9	15	22.11	33.56	15.00	9.0	22.0	24.75	12.0	50	14.0 x 5.5	12.38	10.0	20.0	836
500	9	15	27.73	37.73	15.00	9.0	22.0	25.88	12.0	50	14.0 x 5.5	12.94	10.0	20.0	996
600	19	26	28.79	41.17	17.00	10.0	25.13	29.75	13.5	60	18.0 x 7.0	14.87	11.63	23.26	1485
770	19	26	34.54	46.92	17.00	10.0	25.13	31.88	13.5	60	18.0 x 7.0	15.94	11.63	23.26	1805
800	21.74	29.73	32.54	46.98	19.36	11.37	29.23	35.89	15.37	70	20.0 x 8.0	17.94	13.86	27.72	2300
1000	21.74	29.73	38.55	52.98	19.36	11.37	29.23	36.38	15.37	70	20.0 x 8.0	18.19	13.86	27.72	2870